

## Engineering & Technology second-stage sample tasks

### Section 1. Theoretical mechanics

#### Task 1 (1 point)

Under what conditions is the momentum of a system in an inertial frame of reference conserved

- A) if the line of action of the resultant of all forces passes through the beginning of the reporting system
- B) if the system is closed
- C) if the sum of internal forces is equal to a constant value
- D) if all forces acting on the system are potential.

**Answer:** B) if the system is closed

#### Solution

A mechanical system that is not affected by external forces in the chosen inertial frame of reference is called closed. In this case, the sum of external forces acting on the system is zero. According to the momentum change theorem, the momentum of the system will be constant.

#### Task 2 (1 point)

Find the work done by the elastic force acting from the side of the spring with a stiffness coefficient of  $100 \text{ N/m}$ , when moving from the initial deformed state, in which the absolute deformation was  $0.1 \text{ m}$ , to the final undeformed state.

- A)  $1 \text{ J}$
- B)  $10 \text{ J}$
- C)  $0.5 \text{ J}$
- D)  $5 \text{ J}$ .

**Answer:** C)  $0.5 \text{ J}$ .

#### Solution

According to the potential energy loss theorem, the work done by a conservative force at some displacement is equal to the loss of the corresponding potential energy, which implies

$$A = U_1 - U_2 = \frac{kx_1^2}{2} - \frac{kx_2^2}{2} = 0,5 \text{ J}$$

#### Task 3 (1 point)

Find the magnitude of the force acting on the body if it is known that the moment of this force about the axis is  $20 \text{ N m}$ , and the distance from the axis to the line of action of the force is  $0.1 \text{ m}$ . The line of action of the force belongs to a plane perpendicular to the axis.

- A)  $200 \text{ N}$
- B)  $2 \text{ N}$
- C)  $0.2 \text{ N}$
- D)  $20.1 \text{ N}$

**Answer:** A)  $200 \text{ N}$

#### Solution

The magnitude of the moment of force relative to the axis, provided that the line of action of the force belongs to a plane perpendicular to the axis, is equal to the product of the force and the distance from the line of action of the force to the axis relative to which the moment is calculated.

We get

$$F = \frac{M}{d} = 200 \text{ N}$$

**Task 4 (2 points)**

The law of motion of a point P with a mass of 2 kg is given (the values of the coordinates are indicated in meters)

$$x(t) = 1 + 2t + 3t^2, y(t) = 2 + 4t.$$

Find the absolute value of the speed of the point (expressed in m/s) at the moment 2 s, as well as the magnitude of the force (expressed in N) acting on the body. There are two correct numbers.

- A) 21
- B) 15
- C) 10
- D) 12
- E) 14

**Answer:** B) 15 and D) 12.

**Solution**

Differentiating the laws of motion with respect to time, we find

$$v_x(t) = 2 + 6t, v_y(t) = 4.$$

Finding the second derivative, we obtain the acceleration components

$$w_x(t) = 6, w_y(t) = 0.$$

We substitute the value of time 2 s into the expressions for the velocity and find the components of the velocity vector

$$v_x = 14, v_y = 4.$$

We find the value of the velocity vector 14.56 m/s and, rounding up to integer units *m/s*, we get 15 *m/s*. To calculate the force acting on a point, we use the momentum change theorem

$$F = mw = 12 \text{ H.}$$

**Evaluation criteria:** for 2 correct answers - 2 points, for 1 correct answer - 1 point, no correct answer - 0 points.

**Task 5 (9 points)**

Rod AB of length *l* moves in such a way that points A and B move along mutually perpendicular axes *Ox* and *Oy*, respectively. The velocity of point A is constant. Find the acceleration of an arbitrary point of the rod. Show that the acceleration vector is directed perpendicular to the *Oy* axis and is inversely proportional to the third power of the distance to it.

**Solution:**

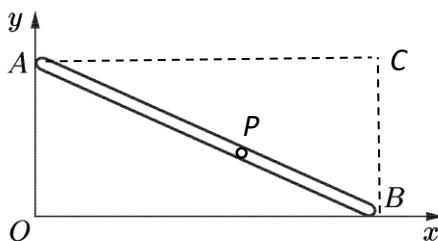

Let us find the acceleration of the rod point P, located at a distance *l<sub>p</sub>* from point A. We use the Rivals theorem for the case of plane-parallel motion

$$\vec{w}_P = \vec{w}_A + \vec{\varepsilon} \times \vec{r}_{AP} - \omega^2 \vec{r}_{AP}$$

where vector  $\vec{r}_{AP} = (l_p \sin \alpha, -l_p \cos \alpha, 0)$ , angle  $\alpha = \widehat{OAB}$ . The angular velocity of the rod and the angular acceleration are found from the relations.

$$\omega = \frac{v_A}{AC} = \frac{v_A}{l \sin \alpha}, \varepsilon = \frac{d\omega}{dt} = \frac{d\omega}{d\alpha} \frac{d\alpha}{dt} = -\frac{v_A^2 \cos \alpha}{l^2 (\sin \alpha)^3}$$

Here point  $C$  is the instantaneous center of velocities,  $v_A$  is the absolute value of the velocity vector of point  $A$ . Taking into account that during plane-parallel motion, the angular acceleration vector has the form

$$\vec{\varepsilon} = (0, 0, \varepsilon)$$

we substitute all the obtained expressions into the Rivals theorem and find

$$\vec{w}_P = (w_x, 0, 0),$$

where the only non-zero component is the component along the x-axis, which has the form

$$w_x = -\frac{a}{x_P^3}$$

The value  $a$  in this expression is a constant value for a fixed point  $P$  equal to

$$a = \frac{v_A^2 l_P^4}{l^2}$$

and the value

$$x_P = l_P \sin \alpha$$

is the distance from the point  $P$  to the y-axis.

**Answer:** the acceleration is directed perpendicular to the Oy axis and is equal to

$$\vec{w}_P = \left( -\frac{a}{x_P^3}, 0, 0 \right)$$

where

$$a = \frac{v_A^2 l_P^4}{l^2}$$

**Evaluation criteria:**

1. Writing down the Rivals theorem: 2 points
2. Calculating the angular velocity of the rod: 2 points
3. Calculating the angular acceleration of the rod: 3 points
4. Calculating the acceleration of the point P: 2 points

**Topic 2. Engineering graphics and basics of designing**

**Task 1. (1 point)**

There is a 3D-model of a part.

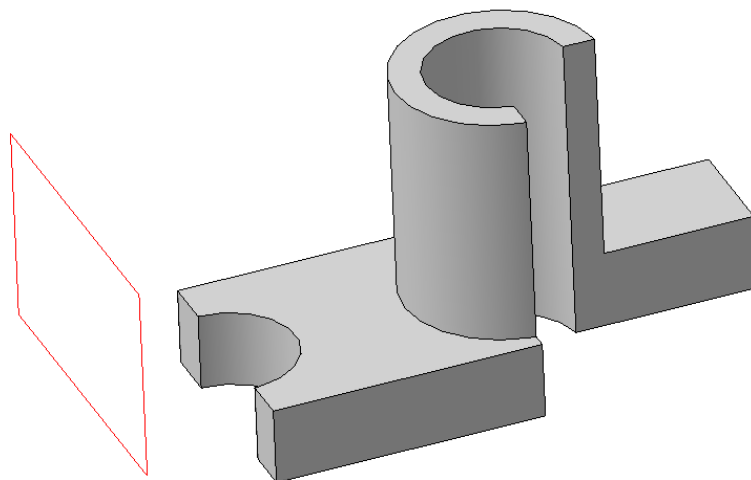

Select a projection view to the designated plane

**ONE CLICK TO OPEN ALL DOORS**

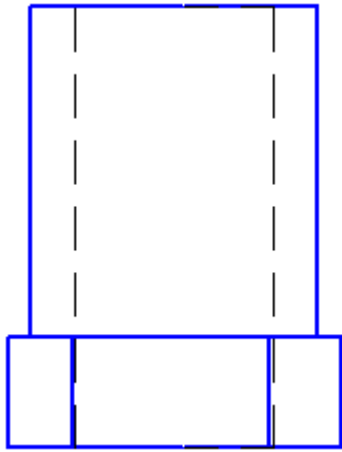

a)

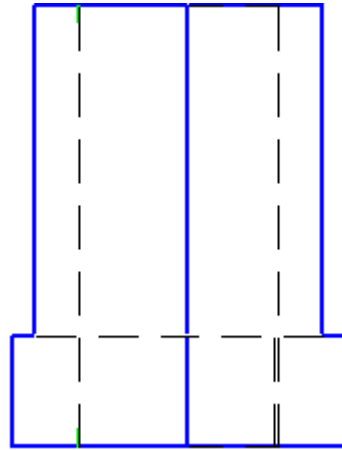

b)

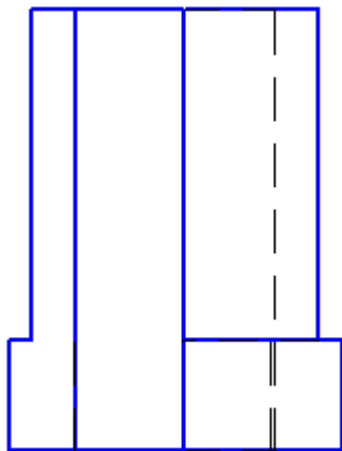

c)

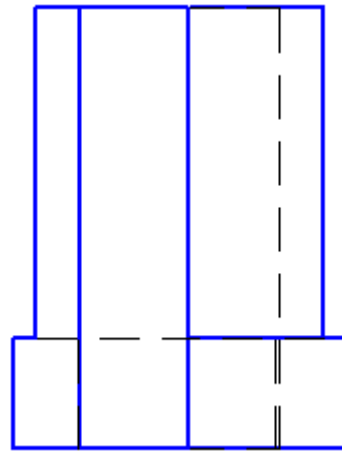

d)

**Answer:** d)

**Task 2. (1 point)**

There is a 3D-model of a part. What type of line should be used in the place of green lines on the projection view?

SECOND STAGE SAMPLE TASKS

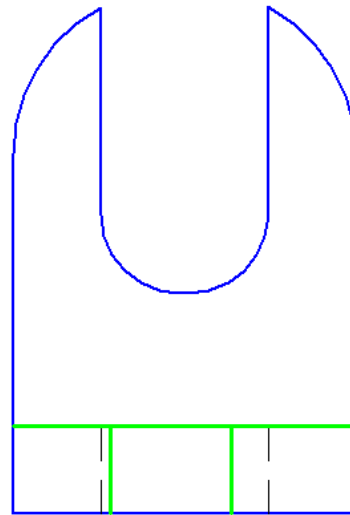
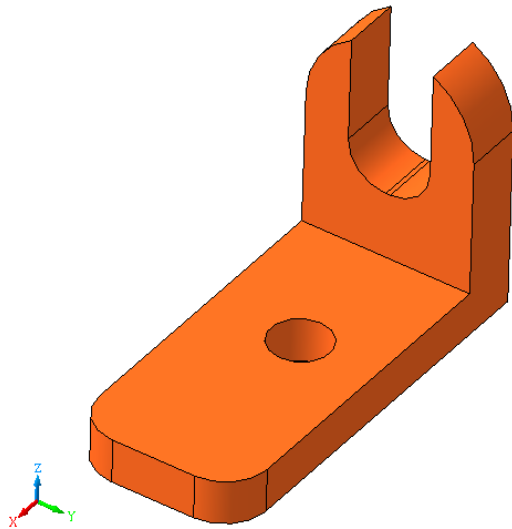

a) 

b) 

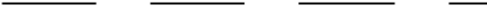
c) 

d) 

Answer: c)

**Task 3 (1 point)**

There is a CNC milling machine program developed in the G-code language:

```
G01 X10 Y40
G0_ X70 Y40
```

The figure shows the trajectory of a drill moving.  
The starting position of the drill is (0,0).

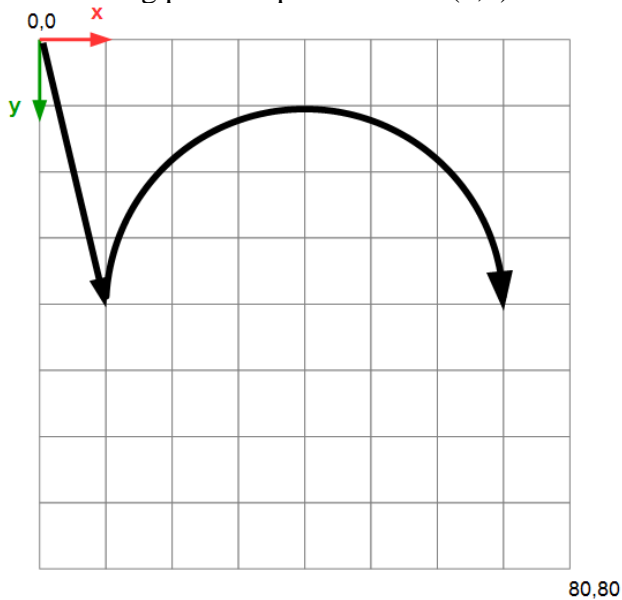

What symbol is missing in the text of the program at the location marked with '\_'?

- a) 1
- b) 2
- c) 3
- d) 7

**Answer:** b)

**Task 4. (2 points)**

Which of the parts are disks?



a)



b)



c)



d)

**Answer:** b) and c).

**Task 5. (9 points)**

This part, produced using a 3D printer, is shown with dimensions in millimeters. It includes a through hole and is made from ABS plastic with a density of  $0.00104 \text{ g/mm}^3$

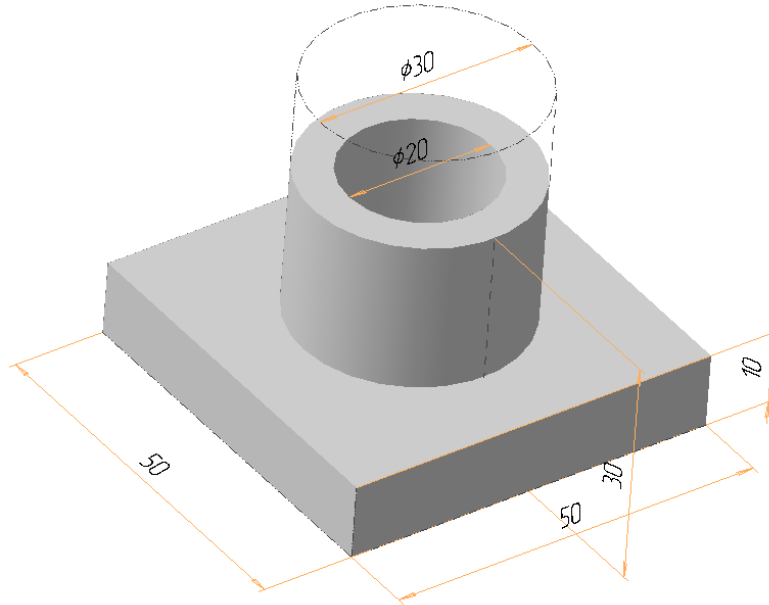

Calculate the mass of this part. The fill factor is 25%. The answer should be in grams, rounded up to the nearest whole number.  $\pi=3.14$ .

**Solution**

The part consists of several smaller parts having different volumes. Sizes are in millimeters.

Volume of the base:

$$V = l \cdot w \cdot h, \text{ where } l - \text{length, } w - \text{width, } h - \text{height.}$$

$$V_{\text{base}} = 50 \cdot 50 \cdot 10 = 25000 \text{ (mm}^3\text{)}$$

Volume of the cylindrical parts calculated as:

$$V = \pi \cdot r^2 \cdot h, \text{ where } r - \text{cylinder radius, } h - \text{cylinder height}$$

Top cylindrical part volume:

$$V_{\text{top}} = 3.14 \cdot (30/2)^2 \cdot 20 = 14130 \text{ (mm}^3\text{)}$$

Volume of hole:

$$V_{\text{hole}} = 3.14 \cdot (20/2)^2 \cdot 30 = 9420 \text{ (mm}^3\text{)}$$

Volume of the whole part:

$$V = V_{\text{base}} + V_{\text{top}} - V_{\text{hole}} = 25000 + 14130 - 9420 = 29710 \text{ mm}^3$$

Given that the part is not fully filled, let us use the fill factor  $k$ . Therefore, the actual volume of material is:

$$V_{\text{fact}} = k \cdot V$$

$$V_{\text{fact}} = 0.25 \cdot 29710 = 7427.5 \text{ (mm}^3\text{)},$$

mass of part

$$m = \rho \cdot V_{\text{fact}}$$

$$m = 0.00104 \cdot 7427.5 = 7.7246 \text{ (g).}$$

Mass should be rounded up to the large side integer  $m = 8\text{g}$

**Answer: 8**



## Section 3. Mechanics of a Deformable Solid Body

### Task 1 (1 point)

What is the dimension of stress, expressed in terms of the basic units of length  $L$ , time  $T$ , mass  $M$ .  $[\sigma]=?$

#### Solution

The dimension of stress is equal to the dimension of pressure (force divided by area).

$$[\sigma]=\frac{M}{T^2L}.$$

### Task 2 (1 point)

Find the reaction in the hinged support for the beam of length  $l$ , shown in Fig. 1.1 Assume that  $a=l/2$ .

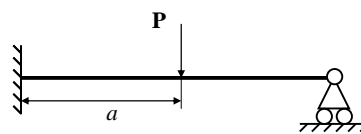

Fig. 1.1

#### Solution

The system is statically indeterminate and requires one additional equation to the system of static equations. Let us replace the bonds with the corresponding reactions (Fig. 1.2) and compose a system of equations.

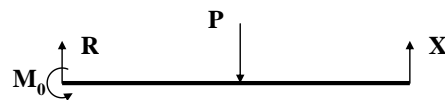

Fig. 1.2

Static equations:

$$M_0 = -Pa + Xl, \quad (1.1)$$

$$R_0 = -P + X. \quad (1.2)$$

An additional equation is given by Castigliano's theorem:

$$\frac{\partial W}{\partial X} = 0. \quad (1.3)$$

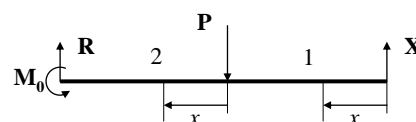

Fig. 1.3

SECOND STAGE SAMPLE TASKS

Let's find the internal bending moment  $M(z)$  in an arbitrary section of the beam. It is convenient to split the beam into two parts and count the coordinate from the right end in order to exclude the influence of reactions at the left end.

For the first part ( $0 < z < l - a$ ):

$$M(z) = Xz. \quad (1.4)$$

For the second part ( $0 < z < a$ ):

$$M(z) = X(l - a + z) - Pz. \quad (1.5)$$

Substituting expressions (1.4) and (1.5) into (1.3), we obtain

$$\begin{aligned} \int_0^l M \frac{\partial M}{\partial X} dz &= \int_0^{l-a} M \frac{\partial M}{\partial X} dz + \int_0^a M \frac{\partial M}{\partial X} dz = \\ &= \int_0^{l-a} Xz^2 dz + \int_0^a (X(l - a + z) - Pz)(l - a + z) dz = 0. \end{aligned}$$

Taking the integral, we get the desired reaction

$$X = \frac{P}{2} \left( \frac{3(l/a) - 1}{(l/a)^3} \right). \quad (1.6)$$

For  $a = l/2$ , we get  $X = \frac{5}{16} P$ .

You must choose one correct answer from the given options

$$X = \frac{5}{16} P \quad X = \frac{5}{8} P \quad X = \frac{3}{16} P \quad X = \frac{4}{25} P$$

**Task 3 (1 point)**

A rod made of plastic material (see the diagram below) is subjected to longitudinal deformation according to the law shown in the figure. The yield limit of a dry friction element is  $\sigma_0 < E_1 \varepsilon_{\max}$ . Find the amount of heat  $Q$  ( $\text{J/m}^3$ ) dissipated in the process.

Let  $E_1 = E_2 = 8\sigma_0$ ,  $\varepsilon_{\max} = 1.01\sigma_0/E_1$ ,  $\sigma_0 = 10^8 \text{Pa}$ .

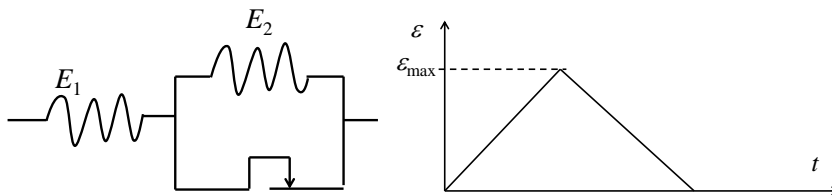

**Solution**

The desired value is equal to the area of the shaded area in the figure.

$$Q = \sigma_0 \varepsilon_{res}.$$

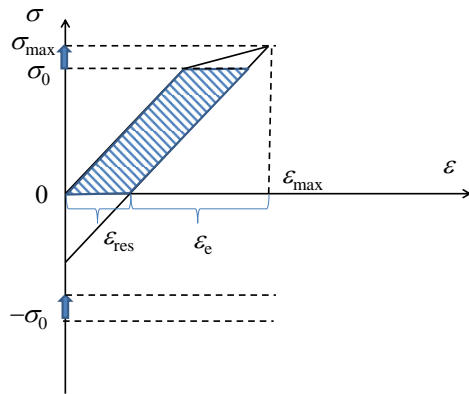

From the figure, it is obvious that

$$\varepsilon_{res} = \varepsilon_{max} - \varepsilon_e$$

$$\varepsilon_e = \sigma_{max} / E_1$$

$$\sigma_{max} = \sigma_0 + (\varepsilon_{max} - \sigma_0 / E_1) \frac{E_1 E_2}{E_1 + E_2}.$$

Finally

$$Q = \sigma_0 \left( \varepsilon_{max} - \sigma_0 / E_1 + (\varepsilon_{max} - \sigma_0 / E_1) \frac{E_2}{E_1 + E_2} \right) = \sigma_0 (\varepsilon_{max} - \sigma_0 / E_1) \left( 1 + \frac{E_2}{E_1 + E_2} \right) = 1.5 \cdot 10^6 Pa.$$

You must choose one correct answer from the given options

1.5 · 10<sup>6</sup>

10<sup>7</sup>

3 · 10<sup>6</sup>

1.5 · 10<sup>5</sup>

**Task 4 (2 points)**

Consider a cantilevered beam of length  $l$  with a free end. Let an external concentrated force  $P$  be applied to the beam at a distance  $a$  from the fixed end. Initially, the beam was strictly horizontal. It is required to find the displacement  $y_1$  of the free end of the beam and the displacement  $y_2$  of the point of application of the force in the vertical direction from the initial position (see Fig. 3.1).

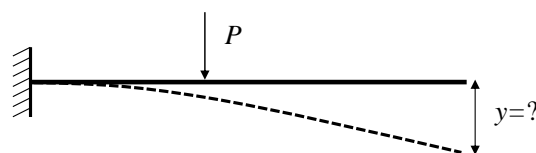

Fig. 2.1

To solve the problem, it is convenient to divide the beam into two parts, as shown in Fig. 3.2. The same figure shows a diagram of the internal bending moment. Using the differential equation of the elastic line of the beam, you can find the general form of the solution in each section. The integration constants are determined from the boundary conditions and the matching conditions at the boundary of the sections (on the boundary, the values  $y$  must match, as well as  $y'$ ).

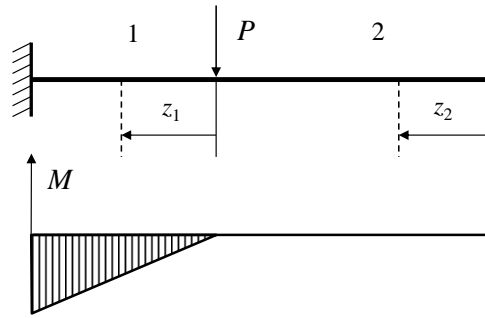

Fig. 3.2

In the part 1, the internal bending moment is equal to

$$M_x(z_1) = -Pz_1. \quad (3.1)$$

Then, we obtain the general expression for the elastic line of the beam in this section:

$$EI_x y' = -P \frac{z_1^2}{2} + C, \quad (3.2)$$

$$EI_x y = -P \frac{z_1^3}{6} + Cz_1 + C_1. \quad (3.3)$$

From the boundary conditions  $y(z_1 = a) = 0$ ,  $y'(z_1 = a) = 0$  we obtain  $C = Pa^2/2$ ,  $C_1 = -Pa^3/3$ . Then finally

$$EI_x y = -P \frac{z_1^3}{6} + P \frac{a^2 z_1}{2} - P \frac{a^3}{3}. \quad (3.4)$$

In the part 2, the internal bending moment is zero. Then

$$y = Az_2 + A_1. \quad (3.5)$$

From matching (3.4) and (3.5) at the boundary of the parts at  $z_2 = l - a$ , on the other hand at  $z_1 = 0$ , we refine the coefficients. The displacements will be equal

$$y_1 = y(z_2 = 0) = A_1 = -\frac{Pa^2}{EI_x} \left( \frac{l}{2} - \frac{a}{6} \right). \quad (3.6)$$

$$y_2 = y(z_1 = 0) = -\frac{Pa^2}{3EI_x}$$

When  $a = l/2$ ,  $y_1 = -\frac{5Pl^3}{48EI_x}$ ,  $y_2 = -\frac{Pl^2}{12EI_x}$

You need to choose from 4 options 2 correct ones:

$$y_1 = -\frac{5Pl^3}{48EI_x}, \quad y_2 = -\frac{Pl^2}{12EI_x}$$

$$y_1 = -\frac{5Pl^3}{24EI_x}, \quad y_2 = -\frac{Pl^2}{3EI_x}$$

**Task 5 (11 points)**

Given a hollow ball made of an isotropic elastic material, the inner and outer surfaces of which are concentric spheres of radius  $a$  and  $b$ , respectively. Pressure  $p_a$  acts in the cavity of the sphere, and pressure  $p_b$  is applied to the outer surface of the sphere.

Find the stress state of the ball if  $a \ll b$ .

**Solution**

The problem exhibits spherical symmetry, with all quantities depending on the current radius. Since the boundary conditions are specified in terms of stresses, it is appropriate to solve the problem using stress-based methods.

We put in the condition of compatibility of deformations

$$\frac{\partial \varepsilon_\theta}{\partial r} + \frac{\varepsilon_\theta - \varepsilon_r}{r} = 0$$

strain components, expressed in terms of stresses using Hooke's law:

$$\varepsilon_r = \frac{1}{E}(T_r - 2\nu T_\theta), \tag{4.1}$$

$$\varepsilon_\theta = \frac{1}{E}(T_\theta - \nu(T_r + T_\theta)). \tag{4.2}$$

As a result, we have the equation

$$\frac{\partial}{\partial r}((1-\nu)T_\theta - \nu T_r) - \frac{1}{r}(T_r - T_\theta)(1+\nu) = 0. \tag{4.3}$$

Using the equilibrium equation

$$\frac{\partial T_r}{\partial r} + 2\frac{T_r - T_\theta}{r} = 0,$$

we reduce (4.3) to the form

$$\frac{\partial}{\partial r}(T_r + 2T_\theta) = 0, \tag{4.4}$$

Equation (4.4) does not contain elastic constants. Integrating, we obtain the condition

$$T_r + 2T_\theta = C, \tag{4.5}$$

where  $C$  is the integration constant.

The sum  $T_r + 2T_\theta$  is the trace of the stress tensor. Thus, according to (4.5), the trace of the stress tensor in this problem does not depend on the distance from the center and is determined only by the boundary conditions. Expressing the component  $T_\theta$  from (4.5) and substituting it into the equilibrium equation, we obtain the equation for the component  $T_r$ :

$$\frac{\partial}{\partial r}T_r + \frac{3}{r}T_r - \frac{C}{r} = 0. \tag{4.6}$$

The solution of the differential equation (4.6) can be easily found and has the form

$$T_r = \frac{C}{3} + \frac{C_1}{r^3}, \tag{4.7}$$

where  $C_1$  is another integration constant. Let us determine the constants  $C_1$  and  $C$  from the boundary conditions. On the inner border  $T_r = -p_a$ , on the outer  $T_r = -p_b$ . Then from (4.7) we obtain

$$C = 3\frac{a^3 p_a - b^3 p_b}{b^3 - a^3} \approx -3p_b, \tag{4.8}$$

$$C_1 = \frac{a^3 b^3}{b^3 - a^3} (p_b - p_a) \approx a^3 (p_b - p_a). \quad (4.9)$$

Substituting the stress values found into (4.1) and (4.2), we find the components of the stress tensor.

**Result:**

$$T_r \approx -p_b - (p_a - p_b) \left( \frac{a}{r} \right)^3$$

$$T_\theta \approx -p_b + \frac{1}{2} (p_a - p_b) \left( \frac{a}{r} \right)^3$$

**Criteria:** The total score is determined by adding the scores for each stage of the solution. The conditions for deformation compatibility are 2 points. Equilibrium conditions are 3 points. Solving the differential equation is 3 points. Determining the components of the stress tensor is 3 points.

## Section 4: Fluid and Gas Mechanics

### Task 1 (Analysis of dimensions, 1 point)

Using dimensional analysis, find the weight flow rate  $G$  through a spillway with a sharp edge representing an angular cutout in a vertical wall. The value of the angle of the cutout is  $\alpha$ .

The apex of the cutout is at a depth  $h$  with respect to the liquid level far from the spillway.

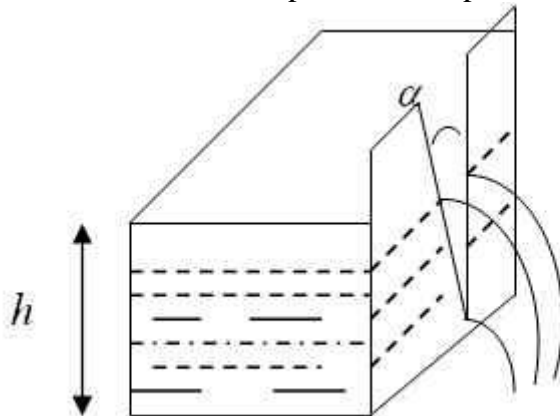

- 1)  $G = f(\alpha) \rho g^{3/2} h^{3/2}$
- 2)  $G = f(\alpha) \rho g^{3/2} h^{5/2} +$
- 3)  $G = g^{3/2} h^{5/2}$
- 4)  $G = g^{1/2} h^{5/2}$

**Answer: 2)  $G = f(\alpha) \rho g^{3/2} h^{5/2}$**

### Solution

The weight flow rate is defined as  $G = Q g$ , where  $Q$  is the mass flow rate,  $g$  is the free fall acceleration. The dimensionality of the weight flow rate  $[G] = [Q][g]$

The main parameters by the problem condition, determining the weight flow rate:  $\rho$  - density,  $g$  - free fall acceleration, depth  $h$ .

## SECOND STAGE SAMPLE TASKS

Define their dimensionality in the MLT class.

$$[G] = \frac{[M][L]}{[T][T]^2} = \frac{[M][L]}{[T]^3}; [\rho] = \frac{[M]}{[L]^3}; [g] = \frac{[L]}{[T]^2}; [h] = [L].$$

$$[G] = f(\alpha) [\rho]^\beta [g]^\gamma [h]^\delta$$

$$\frac{[M][L]}{[T]^3} = \frac{[M]^\beta [L]^\gamma [L]^\delta}{[L]^{3\beta} [T]^{2\gamma}}$$

Compare the degree indices at  $M$ ,  $L$  и  $T$

$$M: 1 = \beta$$

$$L: 1 = -3\beta + \gamma + \delta$$

$$T: -3 = -2\gamma$$

$$\beta = 1, \gamma = \frac{3}{2}, \delta = \frac{5}{2}$$

$$G = f(\alpha) \rho g^{3/2} h^{5/2}$$

### Task 2 (Theory of motion of an ideal fluid, 1 point)

Determine the velocity of steady flow from an ideal liquid tank under the influence of gravity. If the cross-sectional area of the hole  $s = 1 \text{ m}^2$ , the surface area of water in the tank  $S = 25 \text{ m}^2$ , the distance from the hole of the tank to the surface  $h = 45 \text{ m}$ , the acceleration of free fall  $g = 10 \text{ m/s}^2$

Express the velocity in  $\text{m/s}$ , rounded to an integer:

- 1) 30  $\text{m/s}$  +
- 2) 8  $\text{m/s}$
- 3) 2  $\text{m/s}$
- 4) 1  $\text{m/s}$

**Answer: 1) 30  $\text{m/s}$**

#### Solution

$U_1$  is the sinking velocity of the liquid in the tank at the surface.

$U_2$  is the steady-state flow velocity from the tank opening.

The continuity equation:  $S \cdot U_1 = s \cdot U_2$

Since the flow is stationary, the Bernoulli equation is satisfied:

$$P_0 + \frac{\rho U_1^2}{2} + \rho g h_1 = P_0 + \frac{\rho U_2^2}{2} + \rho g h_2$$

where  $P_0$  is the atmospheric pressure,  $h_1 - h_2 = h$

Solving the system of two equations, we get:

$$U_2 = \sqrt{\frac{2gh}{\left(1 - \frac{s^2}{S^2}\right)}}$$

Substituting the numerical values and rounding to integers, we get  $U_2 = 30 \text{ m/s}$ .

### Task 3 (Theory of motion of an ideal fluid, 1 point)

SECOND STAGE SAMPLE TASKS

Select the complex potential that corresponds to the flow pattern illustrated in the figure, where the solid lines represent the streamlines and the dashed lines represent lines of equal potential.

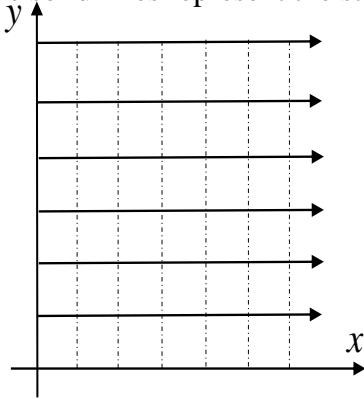

1)  $w = az, a > 0$

2)  $w = \frac{a}{z}, a > 0$

3)  $w = a \ln z, a > 0$

4)  $w = a \ln z, a < 0$

**Answer: 1)**  $w = az, a > 0$

**Solution**

By the definition of complex potential, we can write:

$$\varphi + i\psi = ax + ayi$$

The current lines lie on lines parallel to the x-axis and have the following form:

$$\psi = ay = const$$

Lines of equal potential lie on the lines parallel to the y-axis and have the following form:

$$\varphi = ax = const$$

The velocity throughout the flow is constant and at  $a > 0$  the velocity components are defined as

$$u = \frac{\partial \psi}{\partial y}, \quad v = -\frac{\partial \psi}{\partial x},$$

follows:

$$u = a, \quad v = 0.$$

The complex potential  $w = az$ , with  $a > 0$  corresponds to a homogeneous translational flow parallel to the x-axis.

**Task 4 (Theory of compressible fluid motion, 2 points)**

The equations of motion of an ideal gas and shallow water coincide when

1)  $a = \sqrt{gh}; +$

2)  $a = \sqrt{2gh};$



- 3)  $\gamma = 1$   
 4)  $\gamma = 2+$

**Answer:** 1)  $a = \sqrt{gh}$ ; 4)  $\gamma = 2$

**Solution**

Shallow water equations in the one-dimensional case:

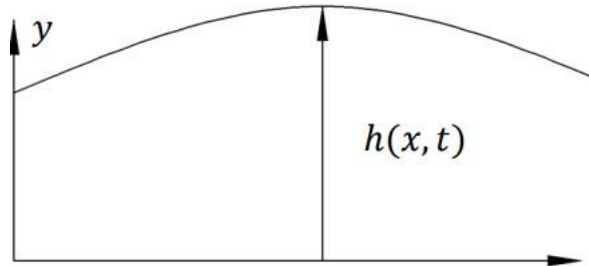

$$h_t + uh_x + hu_x = 0$$

$$u_t + uu_x + gh_x = 0$$

The system is close to that for a compressible fluid when the analog of the speed of sound

*a*:

$$a^2 = gh$$

Let us go from variable  $h$  to variable  $a$

$$h = a^2 / g ;$$

$$h_t = (2 / g) a a_t$$

$$h_x = (2 / g) a a_x$$

$$(2 / g) a a_t + u (2 / g) a a_x + (1 / g) a^2 u_x = 0$$

For a compressible fluid:

$$\rho_t + u\rho_x + \rho u_x = 0$$

$$u_t + uu_x + (a^2 / \rho) \rho_x = 0$$

For an ideal gas:

$$a_t + ua_x + au_x (\gamma - 1) / 2 = 0$$

$$u_t + uu_x + 2 a a_x / (\gamma - 1) = 0$$

In the differential form of the equation entries, the shallow water theory coincides with gas dynamics with adiabatic exponent  $\gamma = 2$

**Task 5 (Theory of viscous fluid motion, 9 points)**

Consider the plane steady-state motion of a viscous incompressible fluid (exact solution of the Navier-Stokes equations) along a circular tube of radius  $R$ . Find an expression for the flow rate and average velocity along the pipe cross-section, as well as their numerical values, considering the pipe radius equal to  $R = 4$  cm, pressure drop  $dP/dx = 0.005$  Pa/m, dynamic viscosity  $\mu = 0.001$  Pa s. Express the flow rate in cubic centimeters per second ( $\text{cm}^3/\text{s}$ ), rounded to the nearest whole number, and the velocity in centimeters per second ( $\text{cm}/\text{s}$ ), rounded to the nearest tenth.

Write their numerical values in the answer.

**Solution**

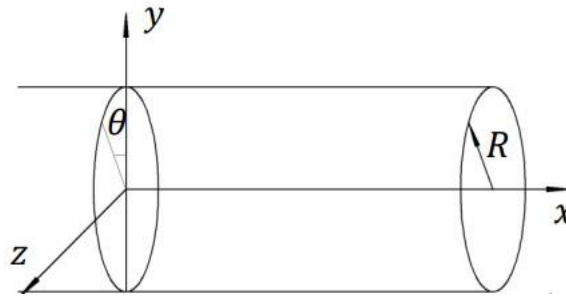

In a cylindrical coordinate system:

$$y = r \cos \theta$$

$$z = r \sin \theta$$

$$u = u(r)$$

$$\frac{\partial^2}{\partial y^2} + \frac{\partial^2}{\partial z^2} = \frac{\partial^2}{\partial r^2} + \frac{1}{r} \frac{\partial}{\partial r} + \frac{1}{r^2} \frac{\partial^2}{\partial \theta^2}$$

The equation of motion of a viscous incompressible fluid:

$$\left\{ \begin{array}{l} \frac{\partial^2 U}{\partial r^2} + \frac{1}{r} \frac{\partial U}{\partial r} = \frac{1}{\mu} \frac{dP}{dx} = \text{const} \\ U_{r=R} = 0 \end{array} \right\}$$

$$\frac{1}{r} \frac{\partial}{\partial r} \left( r \frac{\partial U}{\partial r} \right) = \frac{1}{\mu} \frac{dP}{dx}$$

$$r \frac{\partial U}{\partial r} = \frac{1}{\mu} \frac{dP}{dx} \frac{r^2}{2} + C_1 \ln r + C_2$$

We assume that  $C_1=0$ , since the velocity  $U(0) < \infty$

$$U(r)_{r=R} = \frac{1}{\mu} \frac{dP}{dx} \frac{R^2}{4} + C_2 = 0;$$

$$C_2 = -\frac{1}{\mu} \frac{dP}{dx} \frac{R^2}{4}$$

$$U(r) = -\frac{1}{4\mu} \frac{dP}{dx} (R^2 - r^2)$$

$$\text{Flow rate: } Q = \int_0^R \int_0^{2\pi} U r d\theta dr = -\frac{\pi}{8\mu} \frac{dP}{dx} R^4$$

$$\text{Average velocity over the cross section: } u = \frac{Q}{\pi R^2} = -\frac{1}{8\mu} \frac{dP}{dx} R^2$$

**Answer:  $Q=5 \text{ sm}^3/\text{s}$ ,  $0.1 \text{ sm/s}$**

## Section 5. Automatic control theory

**ONE CLICK TO OPEN ALL DOORS**

**Task 1 (1 point)**

To prove the stability of the point (0,0) of the following dynamical system, which Lyapunov function can be used?

$$\frac{dx_1}{dt} = -x_1x_2^2, \quad \frac{dx_2}{dt} = -x_2 - x_2x_1^2$$

- a)  $V = x_2x_1$
- b)  $V = x_1^2 - x_2^2$
- c)  $V = x_1^4 + x_2^4$
- d)  $V = x_1^2 + x_2^2$

**Solution**

To check stability using the Lyapunov direct method the following conditions should be satisfied  $V(0) = 0, V(x) > 0$  and,  $\dot{V}(x) \leq 0$ .

**Evaluation criteria:** answer (d) – 1 point; (a) or (b) or (c) – 0 points.

**Task 2 (1 point)**

For a linear oscillator with the dynamical equation  $m\ddot{x} + cx = F(t)$  (where  $m$  and  $c$  are mass and spring constant correspondingly and  $F(t)$  is the control force) consider the functional  $\Phi(t_f, x(t_f)) = x(t_f)$  to be maximized.

What is the proposed optimal control  $u = \frac{F(t)}{m}$  to be applied?

Note that  $|u| < u^*$  and  $\omega$  is the frequency of the oscillator.

- a)  $u = \frac{1}{2}u^* \text{sign}(\sin(\omega(t - t_f)))$
- b)  $u = u^* \sin(\omega(t - t_f))$
- c)  $u = u^* \text{sign}(\sin(\omega(t - t_f)))$
- d)  $u = u^* \sin(\omega(t - t_f))$

**Solution:** After forming the Hamiltonian and applying optimality conditions, the control turns out to be a relay control and it can be shown that the sign changes with  $\sin(\omega(t - t_f))$ . This is a well-known example that is mentioned in classical sources of control theory

**Evaluation criteria:** answer (c) – 1 point; (a) or (b) or (d) – 0 point.

**Task 3 (1 point)**

Nyquist plot of  $G(s)$  is given. What is the steady-state error of the closed loop system to step response?

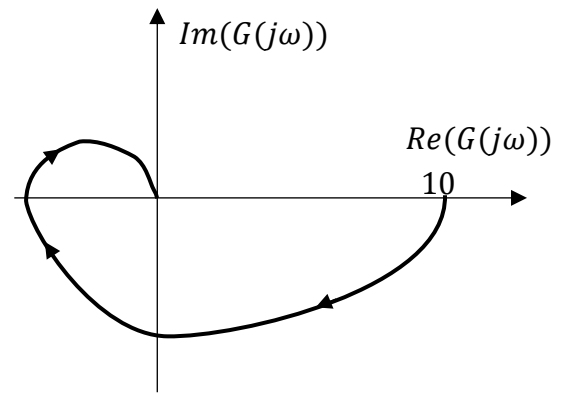
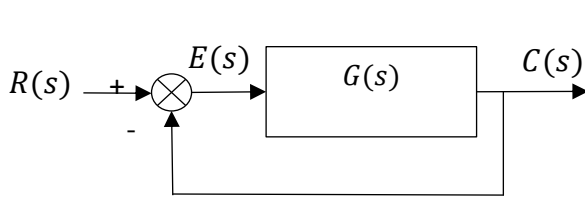

- a) 0
- b)  $\frac{1}{11}$
- c)  $\frac{1}{10}$
- d) 1

**Solution:** As  $GH(0) = 10$  then the steady state error of this system is  $E = \frac{1}{1+GH(0)} = \frac{1}{11}$

**Evaluation criteria:** answer (b) – 1 point; (a) or (c) or (d) – 0 points.

**Task 4 (2 points)**

In the following system, which values of  $K$  guarantees that poles of the system lie on the left side of the line  $\sigma = -1$

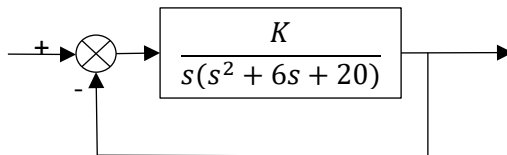

- a) 25
- b) 40
- c) 120
- d) 10

**Solution**

First, the characteristic equation for the closed loop system must be found. Then by changing  $s \rightarrow s - 1$  and using the Routh–Hurwitz method one can find  $15 < K < 45$  in order the system to be stable.

**Evaluation criteria:** answer (a) and (b) – 2 points; (c) or (d) – 0 points.

**Task 5 (9 points)**

For the sys, find the steady state response  $C(t \rightarrow \infty)$  and steady-state error  $E(t \rightarrow \infty)$

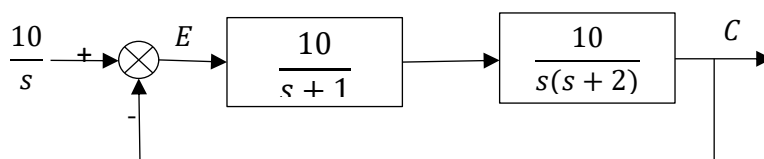

- a) 10,0
- b) 0.975, 10

- c) 1000, 10  
d) 0, 20

**Solution**

To solve the problem having feedback loop with  $H(s) = 1$  and gain  $G(s) = \frac{10}{s+1} * \frac{10}{s(s+2)}$  and considering  $\frac{10}{s} - C(s) = E(s)$  one can use the property from the Laplace Final Value Theorem which states  $\lim_{t \rightarrow \infty} e(t) = \lim_{s \rightarrow 0} sE(s)$  and  $\lim_{t \rightarrow \infty} c(t) = \lim_{s \rightarrow 0} sC(s)$ .

From the block diagram one can obtain  $C(s) = G(s)E(s)$  (\*) and  $(\frac{10}{s} - C(s)) G(s)=C(s)$  (\*\*) which gives:

$$(**) \rightarrow C(s) = \frac{G(s) \frac{10}{s}}{1 + G(s)H(s)} \Rightarrow C = \lim_{s \rightarrow 0} \frac{sG(s) \frac{10}{s}}{1 + GH(s)}$$

$$(*) \rightarrow E(s) = \frac{\frac{10}{s}}{1 + G(s)H(s)} \Rightarrow E = \lim_{s \rightarrow 0} \frac{s \frac{10}{s}}{1 + GH(s)}$$

Substituting and taking limits:

$$C = \lim_{s \rightarrow 0} \frac{s \frac{10}{s+1} * \frac{10}{s(s+2)} \frac{10}{s}}{1 + \frac{10}{s+1} * \frac{10}{s(s+2)}} = 10$$

$$E = \lim_{s \rightarrow 0} \frac{s \frac{10}{s}}{1 + \frac{10}{s+1} * \frac{10}{s(s+2)}} = 0$$

**Evaluation criteria:**

1. Expressing gain G(s) correctly: 2 points
2. Correctly expressing C(s) and E(s): (1+1) (for each one) = 2 points
3. Correctly writing the Final Value Theorem: 3 points
4. Taking limits of  $\lim_{s \rightarrow 0} [sE(s)]$  and  $\lim_{s \rightarrow 0} [sC(s)]$ , and providing the correct final answers: (2+2+3) (if all the previous steps are correct) + (1+1) (each for E(s) and C(s)) = 9 points

Answer (a) – 9 points; (b) or (c) or (d) – 0 points.

**Section 5. Electrotechnics**

**Task 1(1 point)**

A DC circuit schematic is given. Determine the reading of the ideal ohmmeter if  $R_1 = 4 \text{ Ohm}$ ,  $R_2 = 4 \text{ Ohm}$ ,  $R_3 = 2 \text{ Ohm}$ ,  $R_4 = 4 \text{ Ohm}$ .

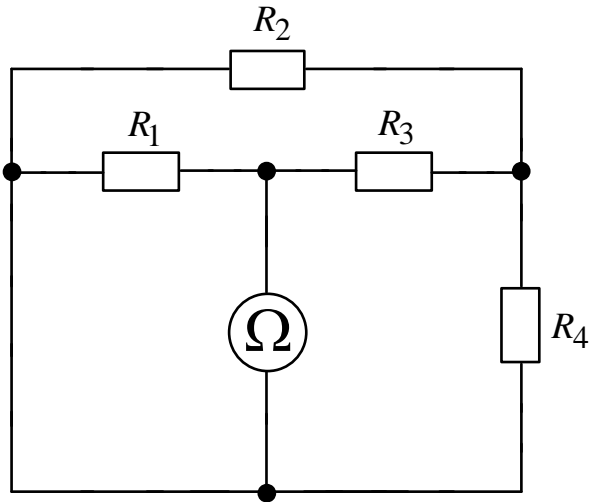

**Solution**

$$R_{\Omega} = \frac{\left(R_3 + \frac{R_2 R_4}{R_2 + R_4}\right) R_1}{R_1 + R_3 + \frac{R_2 R_4}{R_2 + R_4}} = \frac{\left(2 + \frac{16}{4+4}\right) 4}{4 + 2 + \frac{16}{4+4}} = 2 \text{ Ohm}$$

**Answer:** 2 Ohm

**Task 2 (1 point)**

In the circuit the voltage of the source  $U = const$ . The capacitor is not charged. After closing the ideal key  $S$ , determine the expression for the capacitor current  $i_C(t)$ .

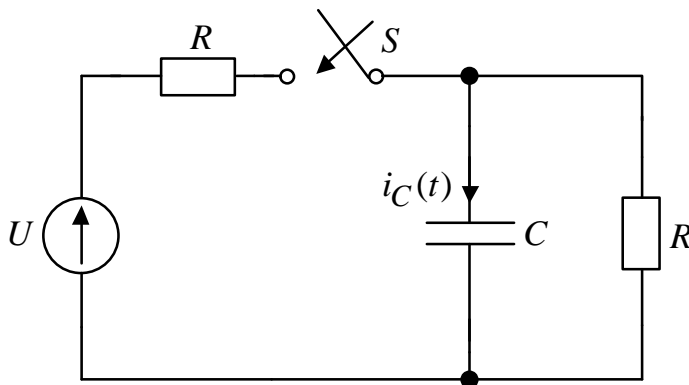

**Solution:**

Consider the mode before the key action when  $t = 0 -$

$$u_c(0 -) = 0 \text{ V}, i_c(0 -) = 0 \text{ A}$$

Consider the mode after the key is triggered when  $t = 0 +$

$$u_c(0 +) = u_c(0 -) = 0 \text{ V} \rightarrow C \equiv \text{short the circuit}$$

$$i_c(0 +) = \frac{U}{R}$$

Consider the forced mode when  $t \rightarrow \infty$ ,  $C \equiv \text{breaking the circuit}$

$$i_c(\infty) = 0 \text{ A}$$

$$i_c(t) = i_c(\infty) + Ae^{-\frac{t}{\tau}}$$

$$A = i_c(0 +) - i_c(\infty) = \frac{U}{R}$$

Calculation of the time constant at  $t > 0$

**ONE CLICK TO OPEN ALL DOORS**

SECOND STAGE SAMPLE TASKS

$$R_3 = \frac{R}{2}, \tau = CR_3 = \frac{RC}{2} \rightarrow i_c(t) = \frac{U}{R} e^{-\frac{2}{RC}t}$$

Answer:  $i_C(t) = \frac{U}{R} e^{-\frac{2}{RC}t}, A$

**Task 3 (1 point)**

A DC circuit schematic is given. Determine the reading of the ideal voltmeter.

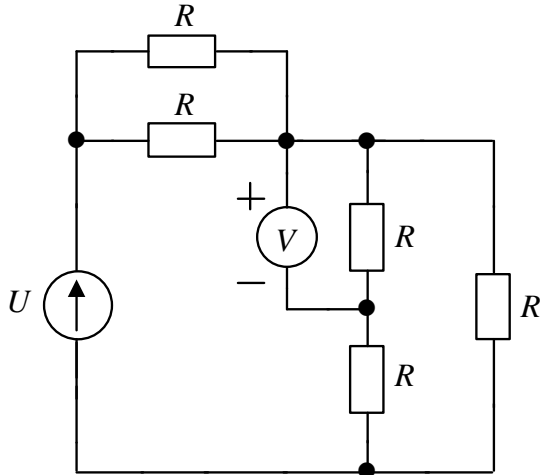

**Solution:**

$$U_V = U \frac{\frac{(R+R)R}{3R}}{\frac{R}{2} + \frac{(R+R)R}{3R}} \cdot \frac{1}{2} = U \frac{\frac{R}{3}}{\frac{R}{2} + \frac{2R}{3}} = U \frac{\frac{1}{3}}{\frac{1}{2} + \frac{2}{3}} = U \frac{1/3}{7/6} = \frac{2U}{7}$$

Answer:  $U_V = \frac{2U}{7}$

**Task 4 (2 point)**

In the circuit the voltage of the source  $u(t) = 100 \cos\left(\frac{t}{4}\right)$ , V.

Circuit parameters:  $R = 1 \text{ Ohm}$ ;  $L = 4 \text{ H}$ ;  $C = 2 \text{ F}$ . It is necessary to determine  $Z_{eq}$ ,  $i(t)$ .

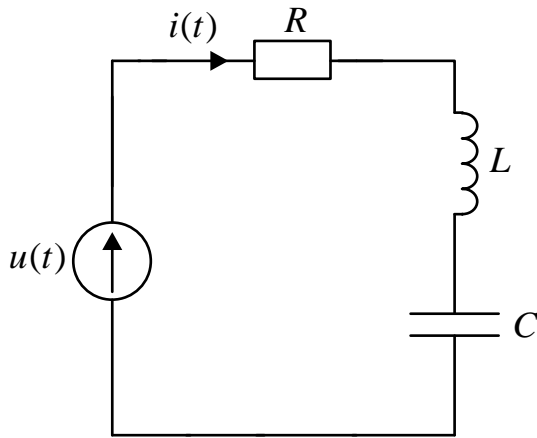

**Solution**

$$Z_R = R = 1 \text{ Ohm}, Z_C = \frac{1}{j\omega C} = -j2 \text{ Ohm}, Z_L = j\omega L = j \text{ Ohm}$$

$$Z_{eq} = Z_R + Z_L + Z_C = 1 - j \text{ Ohm}$$

$$\dot{I}_m = \frac{\dot{U}_m}{Z_{eq}} = \frac{100}{1 - j} = 50 + j50 = 50\sqrt{2}e^{j45^\circ} \div 50\sqrt{2} \cos\left(\frac{t}{4} + 45^\circ\right) \text{ A}$$

**Answer:**  $Z_{eq} = 1 - j \text{ Ohm}; i(t) = 50\sqrt{2} \cos\left(\frac{t}{4} + 45^\circ\right), \text{ A}$

**Task 5 (9 point)**

In the circuit the three-phase power supply is symmetrical, the order of phase alternation is direct (ABC).

Phase voltage of the power supply is  $U_A = 220 \text{ V}$ . Determine the total power complex of a three-phase circuit if  $Z_a = 10 \text{ Ohm}; Z_b = j20 \text{ Ohm}; Z_c = -j10 \text{ Ohm}$ .

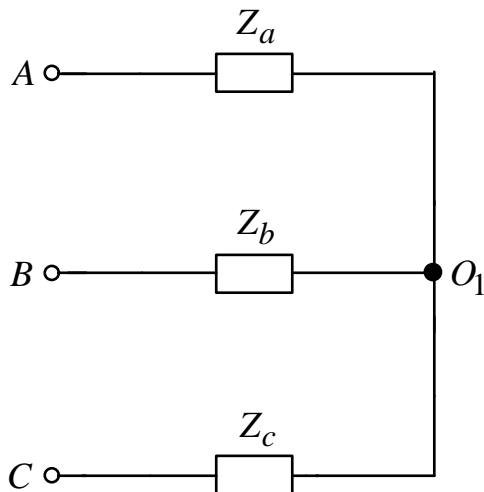

**Solution**

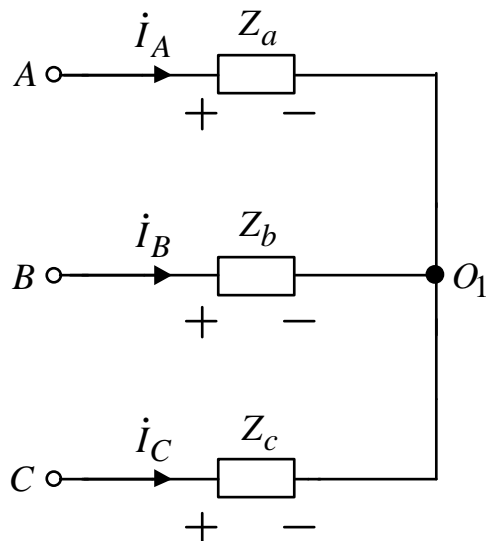

**Solution**

$$\dot{U}_A = 220e^{j90^\circ} = j220 \text{ V}, \quad \dot{U}_B = 220e^{-j30^\circ} = 110\sqrt{3} - j110 \text{ V},$$

$$\dot{U}_C = 220e^{-j150^\circ} = -110\sqrt{3} - j110 \text{ V}$$

$$\dot{U}_{O_1} = \frac{\dot{U}_A Y_a + \dot{U}_B Y_b + \dot{U}_C Y_c}{Y_a + Y_b + Y_c} = 17,685 - j74,631 \text{ V}$$

$$\dot{I}_A = (\dot{U}_A - \dot{U}_{O_1}) Y_a = -1,768 + j29,463 \text{ A}$$

$$\dot{I}_B = (\dot{U}_B - \dot{U}_{O_1}) Y_b = -1,768 - j8,642 \text{ A}$$

$$\dot{I}_C = (\dot{U}_C - \dot{U}_{O_1}) Y_c = 3,537 - j20,821 \text{ A}$$

$$\tilde{S} = U_A \dot{I}_A + U_B \dot{I}_B + U_C \dot{I}_C \approx 8709 - j2902 \text{ VA}$$

**Answer:**  $\tilde{S} \approx 8709 - j2902 \text{ VA}$

**Section 7. Electronics****Task 1 (1 point)**

What is the cellular frequency?

1. 0,9 – 5,0 GHz.
2. 50 Hz.
3. 27,135 MHz.
4. 10 MHz.
5. 470 – 790 MHz/
6. 456 KHz

**Answer.** 1.

**Task 2 (1 point)**

A transistor amplifier with a common emitter operates at an average frequency,  $R_1 = 10 \text{ KOhm}$ ,  $R_2 = 20 \text{ KOhm}$ ,  $R_{inO\Theta} = 1,5 \text{ KOhm}$ ,  $U_{\Pi} = 9 \text{ v}$ . What is the input resistance  $R_{in}$ ?

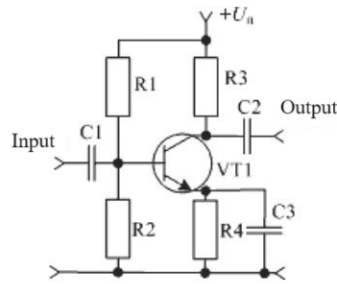

**Answer: 2**

1. 892 Ohm.
2. 1224,5 Ohm.
3. 934 Ohm.
4. 910 Ohm.
5. 983 Ohm.
6. 968 Ohm.

**Solution**

At medium frequencies, the input capacitance of the transistor has no effect, so we do not display

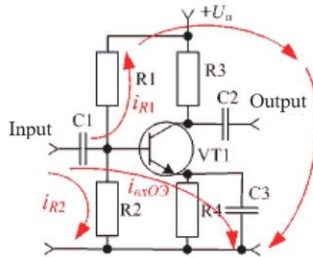

it on the equivalent circuit. The resistance of the capacitor C3 at medium frequencies  $R_{C3} = 1/\omega C = 1/2\pi f$  is close to zero. For clarity, we depict the currents in all circuits. Because all circuit elements are parallel, then  $R_{in} = R1 \parallel R2 \parallel R_{inOЭ} / (R1 \parallel R2 + R2 \parallel R_{inOЭ} + R1 \parallel R_{inOЭ}) = 10 \cdot 10^3 \parallel 20 \cdot 10^3 \parallel 1,5 \cdot 10^3 / (10 \cdot 10^3 \parallel 20 \cdot 10^3 + 20 \cdot 10^3 \parallel 1,5 \cdot 10^3 + 10 \cdot 10^3 \parallel 1,5 \cdot 10^3) = 1224,5 \text{ Ом}$ .

**Task 3 (1 point)**

The strain gauge signal amplifier measures strain. In this setup, a strain gauge denoted as  $R1 = R0 + \Delta R$  is integrated into the differential circuit, while another strain gauge,  $R2 = R0$ , is intentionally configured to counteract external noise. Calculate the currents at node "a" and determine the output voltage  $U_{out} = f(\Delta R)$ . Assume the operational amplifier (OA) behaves ideally, implying  $I_{oy} = 0$ ,  $U_{+in} = U_{-in} = 0$ , and  $|E_{+\pi}| = |E_{-\pi}| = E_{\pi} = 9 \text{ V}$ . The feedback resistance is denoted as  $R_{os} = 1 \text{ kOhm}$ , the initial strain gauge resistance is  $R0 = 400 \text{ Ohm}$ , and the maximum change in resistance,  $\Delta R$ , due to an external load is given as  $\Delta R = 10 \text{ Ohm}$ .

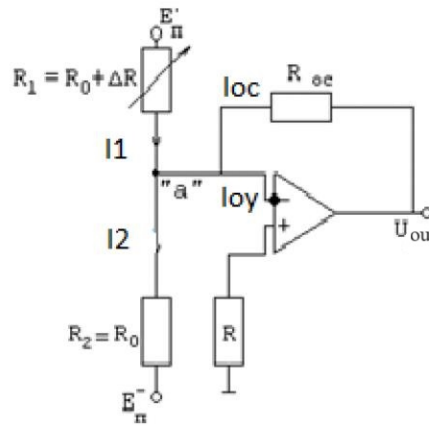

1. 0,60.
2. 1,28.
3. 1,02.
4. 3,09.
5. 0,76.
6. 2,04.

**Answer:** 1.

**Solution.** For node “a”, according to the first Kirchhoff law, the currents are

$I_1 - I_2 = I_{op} + I_{os}$ , as shown in the figure, where

$I_1 = (E^+_{\pi} - U_{in}) / (R_0 - \Delta R)$ ,  $I_2 = (E^-_{\pi} - U_{in}) / R_0$ ,  $I_{oc} = (U_{in} - U_{out}) / R$ , then

$$(E^+_{\pi}) / (R_0 - \Delta R) - (E^-_{\pi}) / R_0 = (-U^+_{out}) / R,$$

$$U_{out} = -R_{oc} E(R_0 - R_0 - \Delta R) / (R_0 - \Delta R) R_0 = E \cdot \Delta R \cdot R_{oc} / R_0^2 = 9 \cdot 10 \cdot 10^3 / (1,6 \cdot 10^5 - 10^3 \cdot 10) = 0,6 \text{ V}.$$

**Task 4 (2 points)**

A triangular periodic signal consists of sinusoids according to the Fourier expansion:

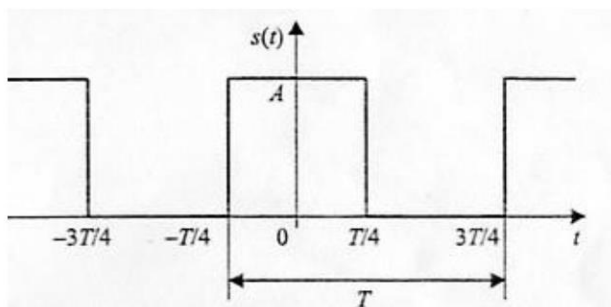

$$s(t) = \frac{A}{2} + \frac{2A}{\pi} \left( \cos\left(\frac{2\pi}{T}t\right) - \frac{1}{3} \cos\left(3\frac{2\pi}{T}t\right) + \frac{1}{5} \cos\left(5\frac{2\pi}{T}t\right) - \dots \right)$$

What type of generator connection ensures the generation of a rectangular periodic signal? Use the Fourier formula.

Answer. 1 and 2.

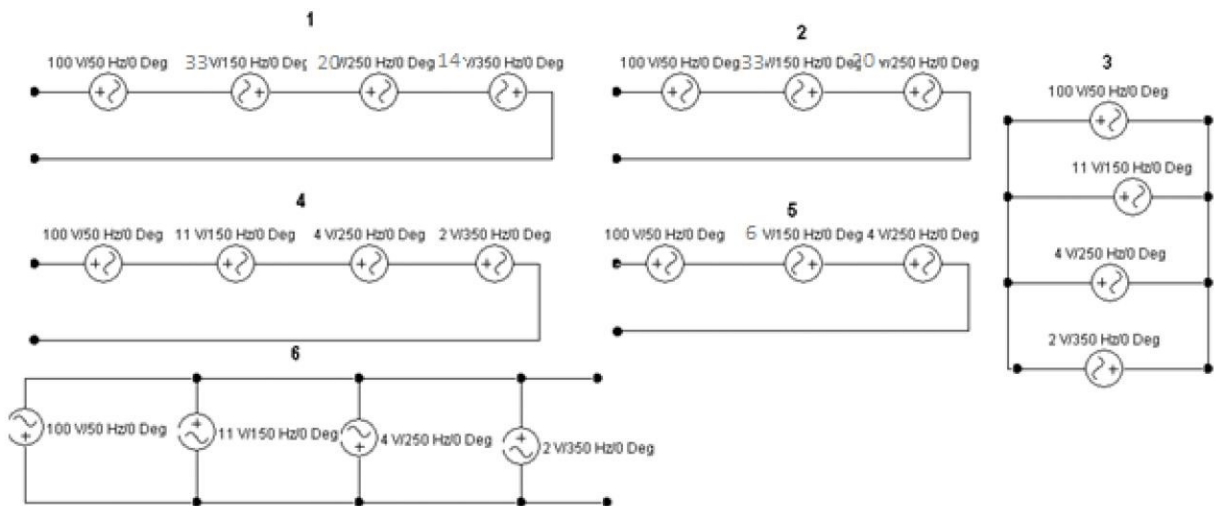

### Task 5 (9 point)

The Wien Bridge Oscillator, using operational amplifier DA1, incorporates a feedback circuit that consists of a series RC circuit connected in parallel with an RC circuit of the same component values. This arrangement creates a phase shift circuit that can either provide phase delay or phase advance depending on the frequency. What is the gain (KU) of the Wien Bridge? What is the oscillation frequency (f) of the Wien Bridge? Which components of the Wien Bridge correspond to the sections of the low-pass and high-pass filters?

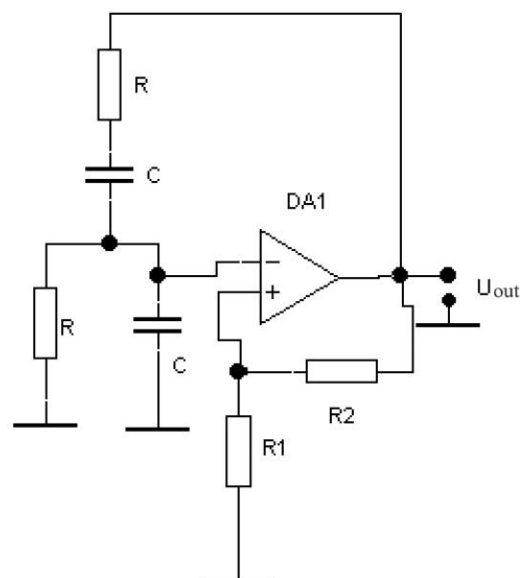

### Solution

The positive feedback comprises two interconnected RC circuits, one in series and the other in parallel. These circuits together create a high-pass filter connected in parallel with a low-pass

## SECOND STAGE SAMPLE TASKS

filter, resulting in a selective second-order band-pass filter. Let us examine the Wien Bridge as a frequency-dependent voltage divider and illustrate its equivalent circuit.

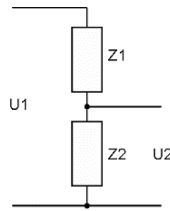

$$K_U = U_2/U_1 = I Z_2/[I (Z_1 + Z_2)], Z_1 = R + 1/j \omega C, Z_2 = 1/(j \omega C + 1).$$

$$K_U = [1/(j \omega C + 1)]/[1/(j \omega C + 1) + R + 1/j \omega C] = 1/3 + j(\omega RC - 1/\omega RC) = 1/3.$$

At the resonant frequency  $f_p = 1/2\pi RC$ , the phase shift is zero,  $\omega_p RC = 1/\omega_p RC$ ,

$$\omega_p = 1/RC = 2\pi f_p, f_p = 1/2\pi RC.$$

The voltage gain of the operational amplifier circuit must be equal to or greater than three for oscillations to start. This is because, as we have seen above, the input is 1/3 of the output.

### Evaluation criteria:

1. For calculating  $K_U$  - 5 points,
2. For calculating  $f_p$  - 1 point,
3. For calculating the values of the components - 1 point for each element,
4. The answer to the question on the frequency filter - 2 points.
5. One point is deducted for each incorrectly specified resistor or capacitor value that deviates from the E24 series.